

BM70 z 1 do 6 sekcji

BM70 from 1 to 6 levers

Charakterystyki ogólne / Technical characteristics		
	l/min GPM	
• Wydatek nominalny / Nominal flow	65	17
• Wydatek maksymalny / Max flow	90	24
• Wydatek maksymalny EO / Max flow EO	65	17
bar PSI		
• Ciśnienie nominalne / Nominal pressure	250	3600
• Ciśnienie nominalne EO / Nominal pressure EO	160	2320
• Max ciśnienie na odbiornikach / Max pressure on ports	320	4700
• Max ciśnienie na powrocie / Max pressure in tank-line	80	1100

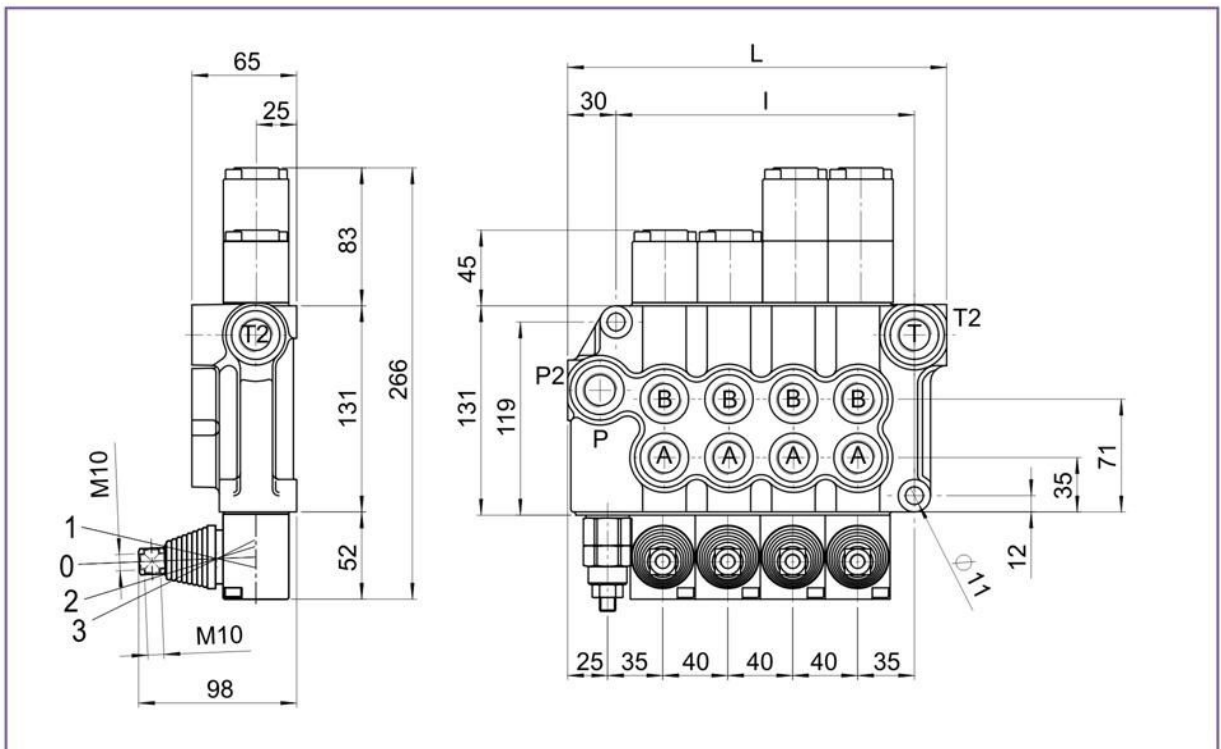
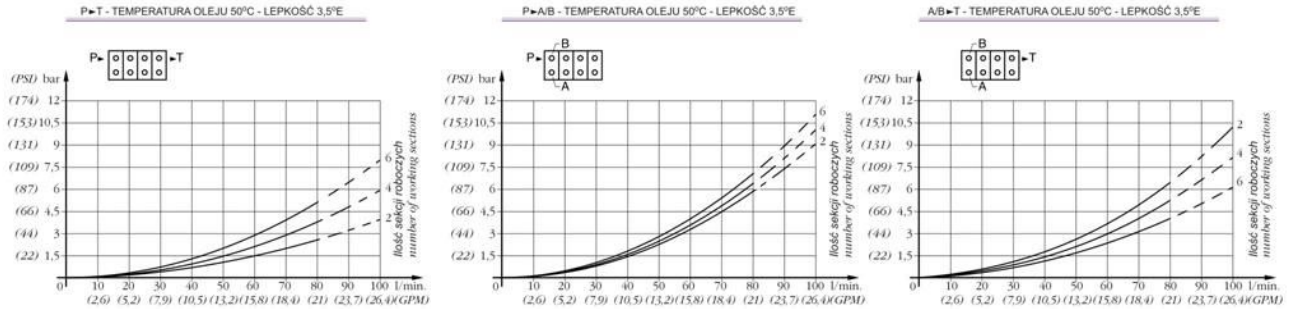

MOD	L	I	Kg
BM70/1	117	66	4,6
BM70/2	157	106	7
BM70/3	197	146	9,2
BM70/4	237	186	11,5
BM70/5	277	226	13,7
BM70/6	317	266	16

GWINTY STANDARDOWE - STANDARD THREAD					
COD	A-B	P	T	P ₂	T ₂
G	1/2"	1/2"	1/2"	3/4"	3/4"
F	7/8" - 14	7/8" - 14	7/8" - 14	1.1/16" - 12	1.1/16" - 12

Na żądanie jest dostępny inny gwint
Other thread available on request

